

THE INSIDE ADVANTAGE™



**CHOOSE QUALITY.....**

# **WHIRLPOOL® BRAND COMMERCIAL LAUNDRY PRODUCTS**

***FEATURING***  
**FACTORY EQUIPPED  
COIN SLIDE AND COIN BOX**



**Reliability, Flexibility, Durability, and Simplicity... From the Industry Leader in Laundry**

## WHIRLPOOL® HOME APPLIANCES. WORLD'S BEST SELLING HOME LAUNDRY\*

It's the 21st century and "good enough" just isn't enough anymore. Your customers expect more from their laundry facility. They want easy to use, large capacity machines that provide many options for quality fabric care.

The entire commercial line-up of Whirlpool® washers and dryers follows with exceptional capacity, cleaning, and drying performance. Each model has combined fabric care options and conveniences that enhance **your power to satisfy each customer's needs.**

### Seven Key Factors to Consider During Your Equipment Selection:

1. Energy Consumption
2. Ease of Use
3. Performance
4. Durability
5. Flexibility
6. Security
7. Warranty

### Coin Store

Customers feel secure knowing that they are using equipment backed by the world's largest manufacturer of laundry products. Our experienced Whirlpool distributors will guide you through every step of creating a new coinstore or retrofitting your existing location.

### Multi-Housing

Whether you choose the convenience of a route operation agreement, or to own and maintain your own equipment, you can trust that Whirlpool® Commercial Laundry has the products to suit the needs of you and your tenants.

Whirlpool Corporation offers some of the most recognized and trusted brands in the world. Brands that your residents trust for quality, reliability and efficiency. As a Property Manager, you need to make the right selection of products for your laundry areas. Choose Whirlpool® Brand Commercial Laundry from the WORLD'S LEADING BRAND of major home appliances!

### University

In the realm of university life, security, reliability and durability are of utmost importance. Let us "educate" you on the advantages of using Whirlpool® Commercial Laundry products featuring mechanical controls. The E-Z connect auxiliary harness makes connection to popular university payment systems fast and simple.

## MAXIMIZE REVENUE

Whirlpool® Commercial Laundry Products featuring factory equipped coin slide and coin box are designed for simplicity, durability and flexibility to meet a variety of needs. A simple mechanical timer and Direct-Drive, NO BELT Washing System offers years of reliable operation at a very competitive price. Every Whirlpool® Washer features the 2 speed advantage, offering a true low speed gentle wash option. A high speed spin of 640 rpm ensures optimal water extraction.

A heavy gauge cabinet with powdered paint top and lid is difficult to dent and resists rust.

## WHIRLPOOL® DIRECT-DRIVE, NO-BELT WASHING SYSTEM

During the service lifetime of a typical Speed Queen® or GE® commercial belt-driven top load washer, it is possible that many belts will need to be replaced. Belt driven washing machines rely on belt slippage to slowly build up spin speed.

Machines get overloaded — Belts wear — Belts break — and your machine is out of commission.

### WHY SETTLE FOR 50 YEAR OLD BELT-DRIVEN TECHNOLOGY?

Whirlpool® Direct-Drive, NO-BELT, enclosed clutch washers eliminate the need for belts. Whirlpool® brand Direct-Drive washer motor coupler isolators feature a heavy duty automotive design. They have been tested to 20,000 cycles without failure!\*

No belts equate to less hassle, fewer repairs, and an uninterrupted income stream for you.

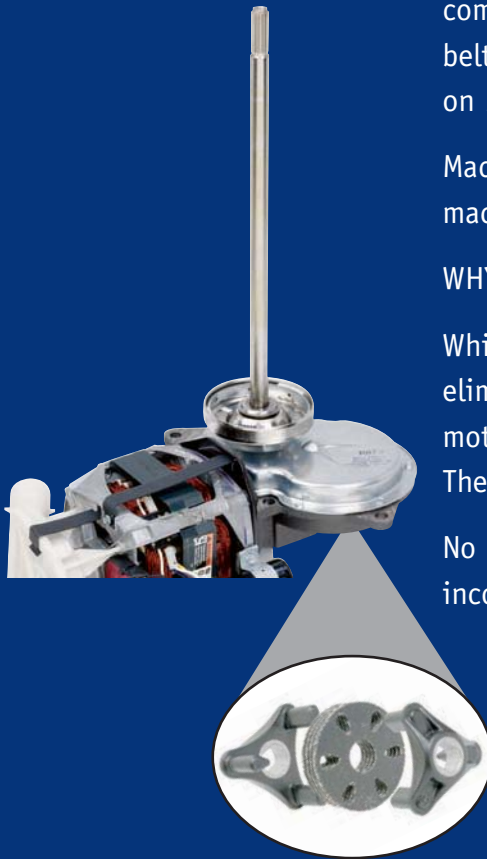

VS



**One Durable Whirlpool® Motor Coupler Isolator can be Equivalent to Many Competitive Product Belts!**

**WHIRLPOOL**

**THE COMPETITION**

**Maximize the Efficiency and Profitability of your Laundry Area with Whirlpool® Brand Commercial Laundry Products Featuring Factory Equipped Coin Slide and Coin Box**

\*Whirlpool Lab Testing, 2001.

SPEED QUEEN is a registered trademark of Alliance Laundry Systems, LLC.

GE is a registered trademark of General Electric Corporation.

For warranty details, see information packed with your product. Call 1-800-NO-BELTS or visit [www.coinop.com/warranty.asp](http://www.coinop.com/warranty.asp)

## HIGH EFFICIENCY COMMERCIAL WASHER

Featuring Factory Installed Coin Slide and Coin Box



### CAM2742TQ — 27" 2-Speed Washer with Factory Installed Coin Slide and Coin Box

**EXCLUSIVE! 1 YEAR FACTORY LABOR WARRANTY!**

- 3.2 Cu. Ft. Wash Basket, 18 Lbs. UL
- 2 Piece Auger Agitator for Improved Washability
- Push Button Controls
- High Efficiency, Low Water Factor
- 3 Cycles: Heavy (Hot/Cold), Permanent Press (Warm/Cold) and Colorfast (Cold/Cold) to Provide the Right Washing Conditions for a Wide Range of Fabrics
- Two-Speed Advantage with True Gentle Wash, High Speed Spin Only!
- Deep Rinse System, Automatic Temperature Control 115° H 85° W
- Hidden Lid Switch
- High Speed Spin 640 RPM (Approx.)
- Galvanized, Heavy Gauge Cabinet Back Panel
- Heavy Duty Motor Coupler Isolator Tested to 20,000 Cycles!\*
- 1/2-HP Motor with Built-In Overload Protector: 120-Volt, 60 Hz., A.C. Agitation Speed 180 SPM/High 120 SPM/Low
- Reliable, Direct-Drive NO-BELTS Drive System, Front and Bottom Serviceable
- Residential grade inlet hoses and corrugated drain hose included
- 3 Cycle Indicator Lamps
- 23.22 Gallons Minimum Water Usage per Cycle (Low Water Level, 3 Lbs. Load)
- 8 Quarter Coin Slide Capacity, Set Your Wash Price from \$0-\$2 per Cycle (\$1 Factory Preset)
- **1 Year Labor/2 Year Parts Warranty\*\***

\* Testing completed 11/12/2001

\*\* Call 1-800-NO-BELTS for warranty details

To locate a distributor near you, please visit  
[www.coinop.com/distributor](http://www.coinop.com/distributor), or call 1-800-NO-BELTS.

## WHIRLPOOL® BRAND COMMERCIAL WASHERS



### DIRECT DRIVE SYSTEM

27" heavy-duty commercial washers feature the

Direct-Drive, No-Belt washing system for greater reliability, reduced down time and increased profits.

### LARGE CAPACITY WASH BASKET

Ideal for handling family size loads!



### HIGH AND LOW WATER LEVEL

Reduce water consumption to 23.22 gallons per cycle!



### TRIPOD SUSPENSION

Sturdy tripod-suspension with active liquid filled balance ring reduces product weight while balancing commercial size laundry loads.



### RUST PROOF SCREWS

Rust proof Stainless Steel Torx® control panel screws give your machines added security and service life!



### SEALED HIDDEN LID SWITCH

To help ensure safe operation, Whirlpool® commercial washers feature a lid switch that is truly hidden. Not only does this prevent tampering, it ensures that the washer will not operate when the lid is open.

## WHIRLPOOL® BRAND COMMERCIAL DRYERS

### 1/3 HP MOTOR

1/3 HP motor with overload protection.

### THERMOSTAT

Single operating thermostat for simple accurate temperature control.



### IMPROVED AIRFLOW SYSTEM

Whirlpool® commercial dryers have a new

Blower Housing Wave Insert to increase air velocity up to 10%. This increases efficiency, heating element lifespan, and improves fabric care.\*

\*Results per Whirlpool dryer testing conducted 7/03–8/04

### LARGE CAPACITY METERCASE

Larger coinbox for reduced collections.



### LARGE 5.9 CU. FT. DRUM CAPACITY

The increased capacity allows for large loads of clothes to tumble and spread, saving you and your customers drying time and expense.



### LARGE LINT FILTER

Top mounted lint filter.



### SIDE SWING DOOR

For convenient access, the wide-opening side-swing door can be opened a full 180°.

## COMMERCIAL DRYER

Featuring Factory Installed Coin Slide and Coin Box



### CEM2940TQ— 29" Electric Dryer CGM2941TQ— 29" Gas Dryer with Factory Installed Coin Slide & Coin Box

EXCLUSIVE 1 YEAR FACTORY  
LABOR WARRANTY!!

- Large 5.9 Cu. Ft. Drum Capacity
- Push Button Controls with Stainless-Look Console
- 3 Cycles: Regular/Heavy (High Heat), Permanent Press (Medium Heat), and Knits/Delicates (Low Heat)
- Large, Removable, Top Mounted Lint Screen
- 180 Degree Wide-Opening Reversible Side-Swing Door
- Powdered Paint Top, Door and Cabinet for years of Reliable Service
- Electric Model Features Element Rated at 5600 Watts, 240 Volt
- Gas Model Features a 22K BTU Burner
- Motor: 1/3 HP With Built-In Overload Protector; Centrifugal Switch Turns Off Heating Element When Motor Stops
- Easy-to-Follow Console Instructions
- Power Cord Sold Separately (Electric Model Only)
- 8 Quarter Coin Slide Capacity, Set Your Dry Price From \$0–\$2 Per Cycle (\$1 factory preset)
- **1 Year Labor/2 Year Parts Warranty\*\***

\*\*Call 1-800-NO-BELTS for warranty details.

To locate a distributor near you, please visit  
[www.coinop.com/distributor](http://www.coinop.com/distributor), or call 1-800-NO-BELTS.

# COMMERCIAL WASHER SPECIFICATIONS

## WASHER SPECIFICATIONS

<b>MODEL NUMBER</b>	<b>CAM2742TQ</b>
<b>GENERAL INFORMATION</b> Factory installed coin slide and coin box. Set your wash price from \$0-\$2 per cycle (\$1.00 factory present)  Stainless steel look push button console, hidden lid switch, powdered paint finish top, lid and cabinet, galvanized back, improved meter case, inlet hoses and corrugated drain hose included.	High Efficiency Deep Rinse, Electronic Temperature Control, Super Capacity 3.2 Cu. Ft. Basket, High and Low Water Level Settings, 2007 Federal Energy Compliant
<b>MOTOR</b> 120-Volt 1/2-HP Direct-Drive with Built-In Overload Protector	Two-Speed Advantage with True Gentle Wash High Speed Spin Only!
<b>AGITATION STROKES PER MINUTE/AMPERAGE</b>	180 SPM/High (5.0 Amps No Load) 120 SPM/Low (5.0 Amps No Load)
<b>MAXIMUM RATED CURRENT</b>	9.8 Amps (120-Volt)
<b>MOTOR RPM</b>	1725 High, 1140 Low
<b>SPIN RPM</b>	640 High
<b>ELECTRICAL REQUIREMENTS</b> Subject to Local Codes	120V, 60 Hz., A.C. Standard 15 Amp Breaker/Fuse Branch Circuit for Each Washer
<b>DIMENSIONS</b> See Illustration Below	43" H (at Metercase Top), 35" H (at Lid), 27" W, 25.5" D
<b>SHIPPING WEIGHT (EST.)</b>	184 Lbs.
<b>BASKET VOLUME</b>	3.2 Cu. Ft. (18 Lbs U.L.)

Dimensions are for planning purposes only. For complete information, see installation instructions packed with product.

### NEW YORK CITY M.E.A.

PIN	FUNCTION
5 to neutral	Remote cycle start with remote relay closure
1 to 4	Changes state every 30 seconds
3 to 6	Cycle Counter

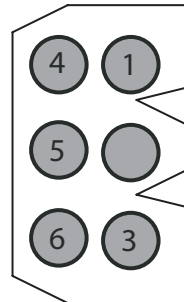

E-Z Wiring Harness Feature Connector for connection to money acceptors (located under top cover)

Energy information is available online at [www.coinop.com/products](http://www.coinop.com/products), WP literature part #CWXL077

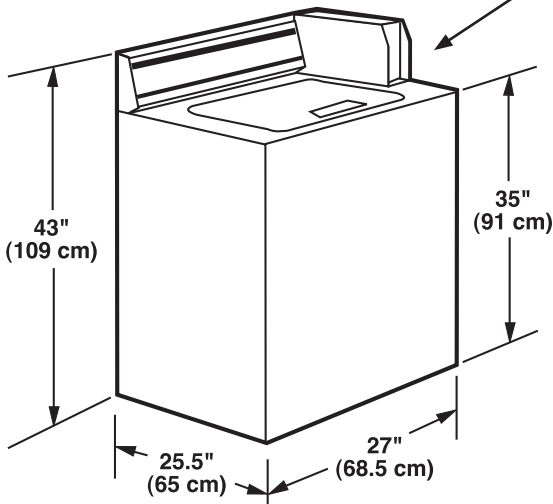

WASHER FRONT VIEW

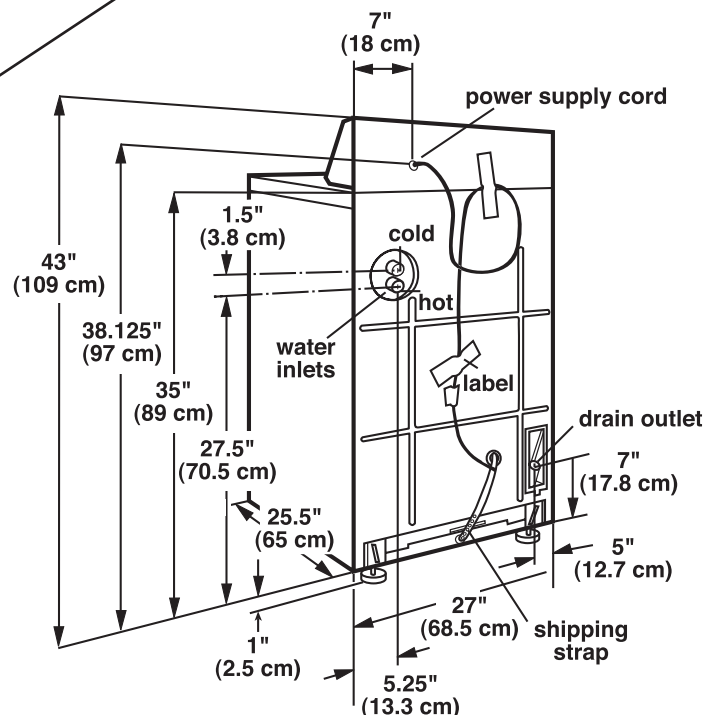

WASHER BACK VIEW

# COMMERCIAL DRYER SPECIFICATIONS

## SINGLE DRYER SPECIFICATIONS

MODEL NUMBER	CEM2940TQ <sup>††</sup>	CGM2941TQ <sup>†</sup>
<b>GENERAL INFORMATION</b> Stainless steel look Push Button console, white enamel drum, powdered paint finish cabinet and top, removable lint filter, improved meter case.	Metercase Model Factory Installed Coin Slide and Coin Box, \$1.00 Factory Preset \$0-2 per Cycle,	Metercase Model Factory Installed Coin Slide and Coin Box, \$1.00 Factory Preset \$0-2 per Cycle,
<b>ELECTRICAL REQUIREMENTS</b>	3-Wire Nominal 240/208V, 60 Hz., A.C. Standard 30-amp Breaker/Fuse Branch Circuit per Dryer (subject to local codes)	Nominal, 120V, 60Hz., A.C., Standard 15-amp Breaker/Fuse Branch Circuit per Dryer (subject to local codes)
<b>MOTOR</b>	<sup>1</sup> / <sub>3</sub> HP Single Speed Motor with Built-In Overload Protector 5.9-amps Max Rating	<sup>1</sup> / <sub>3</sub> HP Single Speed Motor with Built-In Overload Protector 5.9-amps Max Rating
<b>HEATER TYPE</b>	<b>ELECTRIC</b>	<b>GAS**</b>
<b>HEATER/BURNER RATING</b> (Add 500 watts approx for motor on all dryer models)	Heater Rated at 5600 Watts	22,000 BTU/h Natural Gas
<b>OPERATIONAL AMPERAGE</b> (Does not include control or gas valve)	Motor — 4.0-amps No load Heater — 23.33-amps @ 240V 27.33 Total	Motor — 4.0-amps No load
<b>DIMENSIONS</b> See Illustrations	42.875"H*, 29"W, 27.75"D	42.875"H*, 29"W, 27.75"D
<b>SHIPPING WEIGHT (EST.)</b>	147 Lbs.	147 Lbs.
<b>DRUM VOLUME</b>	7.0 Cu. Ft.	7.0 Cu. Ft.

\* (height at meter case top) \*\* Burner orifices are available for manufactured, natural, mixed, and LP gas with varying BTU ratings. <sup>†</sup>LP Conversion Kit: 49572 <sup>††</sup>Power cords on electric models sold separately Energy information is available online at [www.coinop.com/products](http://www.coinop.com/products). WP lit# CWXL077

Dimensions are for planning purposes only. For complete information, see installation instructions packed with product.

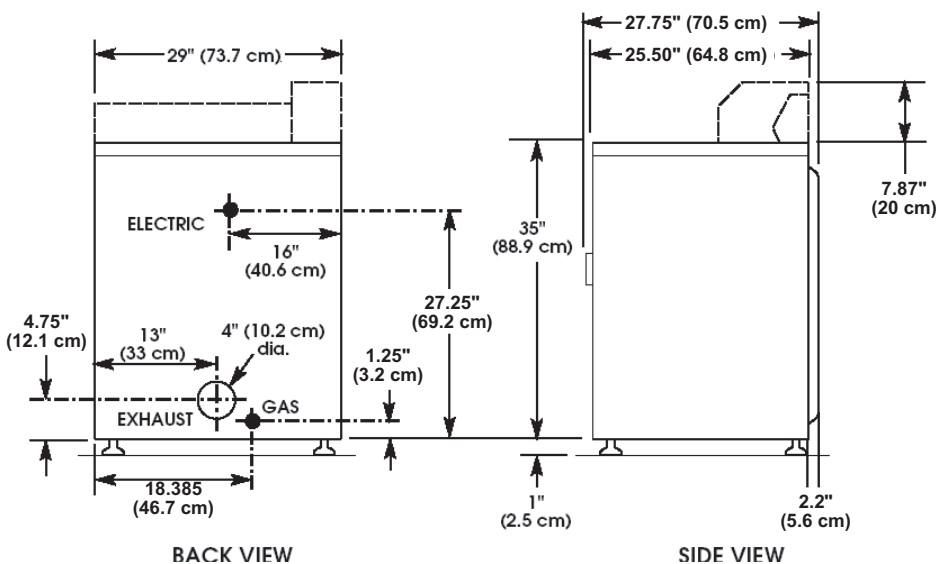

## Exhaust Information

All dryers require the equivalent of a 4-inch diameter exhaust duct. Rigid metal duct is recommended. Failure to properly exhaust the dryer will result in improper operation.

# of 90° Turns	4" Hood	2 1/2" Hood
Maximum Length of 4" Diameter Rigid metal Duct		
0	64 Ft.	58 Ft.
1	54 Ft.	48 Ft.
2	44 Ft.	38 Ft.
3	35 Ft.	29 Ft.
4	27 Ft.	21 Ft.
Maximum Length of 4" Diameter Rigid metal Duct		
0	36 Ft.	28 Ft.
1	31 Ft.	23 Ft.
2	27 Ft.	19 Ft.
3	25 Ft.	17 Ft.
4	23 Ft.	15 Ft.

## MONEY ACCEPTOR PARTS CROSS REFERENCE



KEY	PART NAME	WHIRLPOOL PART NO.	ESD PART NO.
1	Service Door	3351138	N/A
2	Vertical 8 Coin Kit* (Washer and Dryer) Includes 3-9	3954807	72093
3	Key Front Lock or Top Lock	358288	Multiple Options
4	Money Box with Key	8316525	72101-XD
5	Vertical 8 Coin Slide* (Slide Only)	8316520	V8-200 (71689)
6	Coin Slide Extension Washer	8316522	21053
7	Coin Slide Extension Dryer	8316523	21064
8	Bolt Slide Mechanism	8316521	21749
9	Decal Kit	8316524	72097
10	Insert Blank	8316264	21216
11	Insert \$.25	8316265	21193
12	Optional Front Lock Assembly	358290	0300-ETWH
13	Dryer Timer Cams		
	3-Pin (60 Minutes)	3387974	N/A
	4-Pin (45 Minutes)	339855	N/A
	6-Pin (30 Minutes)	343777	N/A
	9-Pin (20 Minutes)**	339854	N/A
12-Pin (15 Minutes)**	339853	N/A	
14	Front Lock Blank	38731	N/A

\*State coinage type (US quarter, US dollar, Canadian quarter, Canadian dollar, etc.). \*\*Optional timing cams available through Whirlpool parts. Modifications may void the Whirlpool Corporation product warranty.



## MONEY ACCEPTOR MANUFACTURER CONTACT INFORMATION

MANUFACTURER	ESD	WHIRLPOOL	GREENWALD*
Address	270 New Jersey Drive Fort Washington, PA 19034	Commercial Laundry Sales 2000 M63, MD4302 Benton Harbor, MI 49022	212 Middlesex Ave. Chester, CT 06412
Phone	1-800-523-1510	1-800-662-3587, option 1	1-800-221-0982
Email	info@esdcoin.com	Byron_W_Hatch@whirlpool.com	sales@greenwaldindustries.com

\*Unit may be factory equipped with either an ESD or Greenwald coin unit.

## WARRANTIES

### EXCLUSIVE 1 YEAR FACTORY LABOR WARRANTY!!

#### WASHER WARRANTIES

<b>2-Year Limited</b> (Parts Only)	Entire Product
------------------------------------	----------------

For important information regarding warranty inclusions, exclusions and limitations, please call 1-800-NO-BELTS.

#### DRYER WARRANTIES

<b>2-Year Limited</b> (Parts Only)	Entire Product
------------------------------------	----------------

For important information regarding warranty inclusions, exclusions and limitations, please call 1-800-NO-BELTS.

## SECURITY FEATURES OFFERED ON ALL WHIRLPOOL® COMMERCIAL LAUNDRY

- Washer and dryer cabinets are designed to be some of the most durable in the industry.
- The hidden lid switch on our washers ensures safe operation and tamper prevention.

Whirlpool® Fabric Care technology provides a tried and true solution for consumers that prefer a top load washer. Whirlpool Corporation has designed a top load washer that is easy to use and delivers exceptional and dependable cleaning performance. Choose Whirlpool® Commercial Laundry for your coin store, multi-housing, and university projects.

Whirlpool Corporation has a Dedicated Sales and Service Staff Committed to the Success of your Commercial Laundry Business. Please Contact us at 1-800-NO-BELTS (1-800-662-3587).

## NOTES



From Whirlpool Corporation — A World Leader in Laundry Products

<http://coinop.com>

TORX is a registered Trademark of Textron Industries, Inc.

®Registered trademark/™Trademark of Whirlpool, U.S.A.

©2007 Whirlpool Corporation. All rights reserved.

Whirlpool Corporation • Benton Harbor, Michigan 49022 U.S.A.