

WHIRLPOOL® BRAND COMMERCIAL WASHERS



DIRECT DRIVE SYSTEM
27" heavy-duty commercial washers feature the Direct-Drive, No-Belt washing system for greater reliability, reduced down time and increased profits.

LARGE CAPACITY WASH BASKET
Ideal for handling family size loads!

PORCELAIN FINISH
Porcelain top and lid finish resists rust, chipping and scratching.



FRONT LOCK READY
Factory installed lock blank provides a visual vandalism deterrent.

To further discourage theft, order optional front panel lock assembly (part #358290) for the added security of tying the front and top panels together.



HIGH AND LOW WATER LEVEL
Reduce water consumption to 23.22 gallons per cycle!



TRIPOD SUSPENSION
Sturdy tripod-suspension with active liquid filled balance ring reduces product weight while balancing commercial size laundry loads.



NEW
RUST PROOF SCREWS
Rust proof Stainless Steel Torx® control panel screws give your machines added security and service life!



NEW
SEALED HIDDEN LID SWITCH
To help ensure safe operation, Whirlpool® commercial washers feature a lid switch that is truly hidden. Not only does this prevent tampering, it ensures that the washer will not operate when the lid is open.



INDUSTRIAL STRENGTH WATER INLET HOSES
Tested to 1100 PSI!

HIGH EFFICIENCY COMMERCIAL WASHER

Featuring Factory Installed Coin Slide and Coin Box



NEW!
Factory Installed Top Lock

2007
Federal Energy
Compliant

MEF 1.42
WF 8.95
RMC 50.6%

CAM2752TQ — 27" 2-Speed Washer with Factory Installed Coin Slide and Coin Box

EXCLUSIVE! 1 YEAR FACTORY LABOR WARRANTY!

- 3.2 Cu. Ft. Wash Basket, 18 Lbs. UL
- 2 Piece Auger Agitator for Improved Washability
- Push Button Controls
- High Efficiency, Low Water Factor
- 3 Cycles: Heavy (Hot/Cold), Permanent Press (Warm/Cold) and Colorfast (Cold/Cold) to Provide the Right Washing Conditions for a Wide Range of Fabrics
- Two-Speed Advantage with True Gentle Wash, High Speed Spin Only!
- Deep Rinse System, Automatic Temperature Control 115° H 85° W
- Porcelain Top and Lid, Rust Proof Stainless Steel Hinges and Console Screws
- Hidden Lid Switch
- High Speed Spin 640 RPM (Approx.)
- Galvanized, Heavy Gauge Cabinet Back, Side and Front Panels, Removable Front Service Panel
- Heavy Duty Motor Coupler Isolator Tested to 20,000 Cycles!*
- 1/2-HP Motor with Built-In Overload Protector: 120-Volt, 60 Hz., A.C. Agitation Speed 180 SPM/High 120 SPM/Low
- Reliable, Direct-Drive NO-BELTS Drive System, Front and Bottom Serviceable
- Extra Long Power Cord and Commercial-Grade, Color-Coded Water Inlet Hoses with Brass Couplings and EDPM Rubber Drain Hose
- 3 Cycle Indicator Lamps
- 23.22 Gallons Minimum Water Usage per Cycle (Low Water Level, 3 Lbs. Load)
- 8 Quarter Coin Slide Capacity, Set Your Wash Price from \$0–\$2 per Cycle (\$1 Factory Preset)
- **1/3/7/10 Year Parts Warranty****

* Testing completed 11/12/2001

** Call 1-800-NO-BELTS for warranty details

COMMERCIAL WASHER SPECIFICATIONS

WASHER SPECIFICATIONS

MODEL NUMBER	CAM2752TQ
GENERAL INFORMATION Factory installed coin slide and coin box. Set your wash price from \$0-\$2 per cycle (\$1.00 factory present) Stainless steel look push button console, hidden lid switch, porcelain finish top and lid, galvanized, extra thick front panel, side and back panels, improved meter case, front panel lock blank factory installed. Commercial-Grade, color-coded water inlet hoses with brass couplings and rubber drain hose included	High Efficiency Deep Rinse, Electronic Temperature Control, Super Capacity 3.2 Cu. Ft. Basket, High and Low Water Level Settings, 2007 Federal Energy Compliant
MOTOR 120-Volt 1/2-HP Direct-Drive with Built-In Overload Protector	Two-Speed Advantage with True Gentle Wash High Speed Spin Only!
AGITATION STROKES PER MINUTE/AMPERAGE	180 SPM/High (5.0 Amps No Load) 120 SPM/Low (5.0 Amps No Load)
MAXIMUM RATED CURRENT	9.8 Amps (120-Volt)
MOTOR RPM	1725 High, 1140 Low
SPIN RPM	640 High
ELECTRICAL REQUIREMENTS Subject to Local Codes	120V, 60 Hz., A.C. Standard 15 Amp Breaker/ Fuse Branch Circuit for Each Washer
DIMENSIONS See Illustration Below	43" H (at Metercase Top), 35" H (at Lid), 27" W, 25.5" D
SHIPPING WEIGHT (EST.)	184 Lbs.
BASKET VOLUME	3.2 Cu. Ft. (18 Lbs U.L.)

Dimensions are for planning purposes only. For complete information, see installation instructions packed with product.

NEW YORK CITY M.E.A.

PIN	FUNCTION
5 to neutral	Remote cycle start with remote relay closure
1 to 4	Changes state every 30 seconds
3 to 6	Cycle Counter

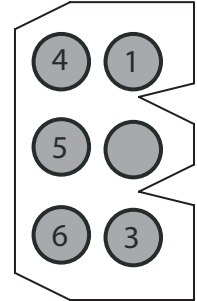

Energy information is available online at www.coinop.com/products, WP literature part #CWXL077

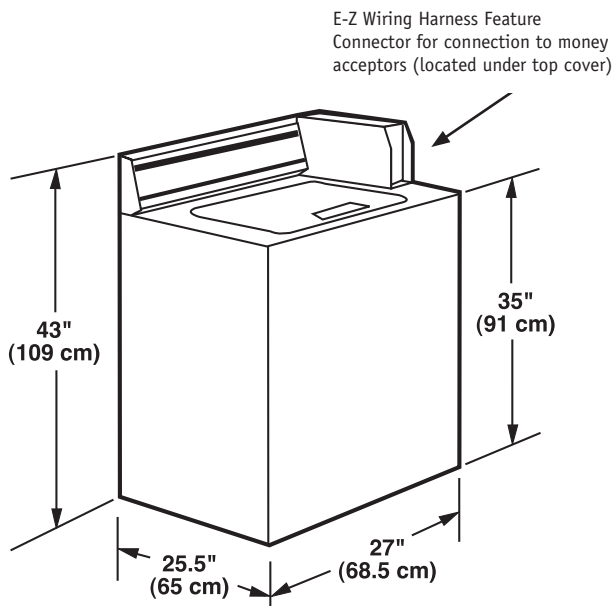

WASHER FRONT VIEW

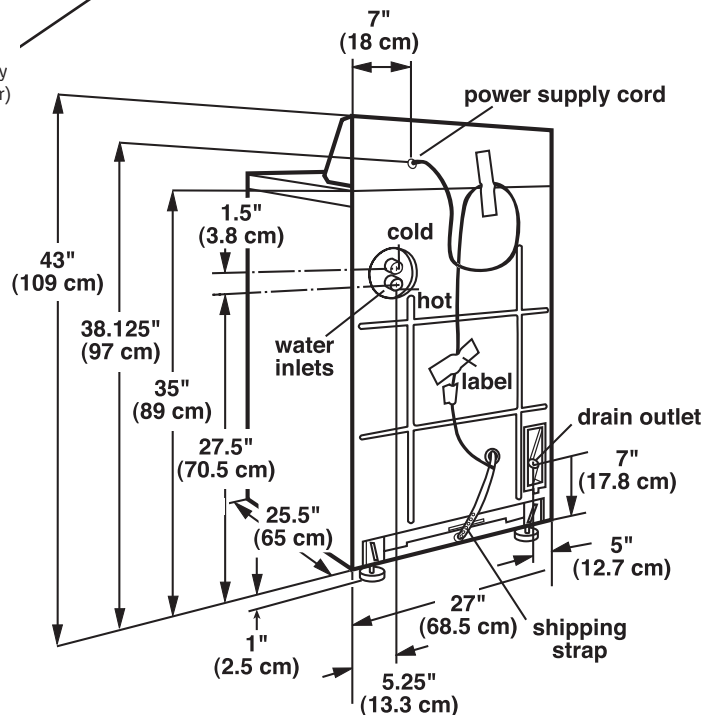

WASHER BACK VIEW